

This camera manual library is for reference and historical purposes, all rights reserved.

This page is copyright by mike@butkus.org M. Butkus, N.J.

**This page may not be sold or distributed without the expressed
permission of the producer**

I have no connection with any camera company

If you find this manual useful, how about a donation of \$3 to: M. Butkus, 29 Lake Ave., High Bridge, NJ 08829-1701 and send your E-mail address too so I can thank you. Most other places would charge you \$7.50 for a electronic copy or \$18.00 for a hard to read Xerox copy. These donations allow me to continue to buy new manuals and maintain these pages. It'll make you feel better, won't it?

If you use Pay Pal, use the link below. Use the above address for a check, M.O. or cash. Use the E-mail of butkusmi@ptd.net for PayPal.



[back to my "Orphancameras" manuals /flash and light meter site](#)

Only one "donation" needed per manual, not per multiple section of a manual !

The large manuals are split only for easy download size.

Canon

EOS REBEL S

EOS REBEL



English Edition
INSTRUCTIONS **E**

Thank you for selecting this Canon product.

It is important to read these instructions carefully before using your camera. The instructions consist of the following four sections:

I. PREPARATIONS FOR TAKING PHOTOGRAPHS

An explanation of the preparations you should carry out before beginning to take photographs.

II. TAKING PHOTOGRAPHS

An explanation of the basic ways of taking photographs.

III. TAKING DIFFERENT KINDS OF SHOTS





An explanation of different ways of taking photographs using the camera's various functions.

IV. OTHER INFORMATION

An explanation of the basic needs for photography and an introduction to some of the accessories that are available.

After reading the instructions on how to use your camera, you will find the information in this section useful to refer back to once you begin using the camera.

Main Features

1. This is the lightest and most compact single lens reflex (SLR) camera in the EOS range (as of September 1993).
 2. A wide autofocus frame, allowing free composition of your photographs.
 3. A simple dial operation which allows you to take photographs exactly as you see them in the image zone.
 4. Silent mechanisms ensuring quiet operation.
- Your new EOS camera can be used with any Canon EF lens. These instructions include an explanation of how to attach EF lenses.
 - The  symbol in this instruction book indicates useful hints when using the camera. The  symbol indicates situations where care should be taken to avoid possible problems.
 - This instruction manual is for use with both the Rebel X S and the Rebel X. However, instructions marked with an  are applicable only to the Rebel X S model (with built-in flash). For more information regarding the  mark, see page 4.



IMPORTANT INFORMATION

This camera will give optimum performance together with specially designed Canon EF lenses, flash units and other Canon brand accessories. It is possible that the use of incompatible lenses or other accessories may result in unsatisfactory performance or damage to your camera. We therefore suggest the use of Canon EF lenses and accessories. Damage to your Canon camera as a result of malfunction or improper connections caused by the use of incompatible products may void its warranty.

I. PREPARATIONS FOR TAKING PHOTOGRAPHS

II. TAKING PHOTOGRAPHS

III. TAKING DIFFERENT KINDS OF SHOTS

IV. OTHER INFORMATION

Precautions.....	4	External LCD Panel.....	9
Taking Photographs Straight Away.....	5	Viewfinder/Internal Information Display.....	9
Nomenclature.....	7	Command Dial.....	10
Attaching the Strap.....	11	How to Attach and Remove Lenses.....	13
Battery Loading and Checking Battery Level.....	11	Shutter Button and Autofocus.....	14
		Loading and Removing Film.....	15
Taking Photographs on the Full Automatic Mode (Q).....	17	Taking Photographs in Portrait Mode (👤).....	21
S The AF Auxiliary Light Emitter.....	18	Taking Photographs in Landscape Mode. (🏞).....	22
S Automatic Flash.....	19	Taking Photographs in Close-up Mode (👤).....	23
S Red-eye Reduction when Using the Flash.....	19	Taking Photographs in Sports Mode (🏃).....	24
Focussing on Subjects at the Edge of the Viewfinder.....	20		
Taking Photographs on the Program AE Settings (P).....	25	Partial Metering.....	39
Program Shift.....	26	Flash Photography with the Speedlite 200E.....	40
Six-second Timer.....	26	Exposure Compensation.....	41
Shutter-priority AE Settings (Tv).....	27	Bulb (Long Exposure) Photography.....	43
Aperture-priority AE Settings (Av).....	29	Multiple-exposure Photography.....	44
Manual Exposure Settings (M).....	31	Taking Pictures Using the Self-timer.....	46
Depth-of-field AE Settings (A-DEP).....	33	Changing the Film Speed Setting.....	47
Flash Photography with the Built-in Flash (Rebel X S only) (🔦).....	35	Shutting off the Beeper after Focussing.....	48
Setting the Red-eye Reduction Function.....	36	Removing Film before the End of the Roll.....	49
Taking Night-time Shots of People.....	37		
Basic Photographic Terms.....	50	AF Mode and Film Winding.....	55
Shutter Speed.....	50	Main Accessories.....	56
Aperture Value.....	50	Canon Speedlite Flashes.....	56
Film Speed (ISO Number).....	51	Remote Switch RS-60E3.....	56
Depth-of-field.....	51	Eye-piece Extender EP-EX15.....	56
Troubleshooting Tips.....	52	Grip GR-80TP.....	57
What to Do If the Exposure Meter on the LCD Panel Blinks.....	53	Camera Case.....	57
List of Functions that can be Used Together.....	54	Dioptic Adjustment Lenses.....	57
		Camera Care.....	58
		Table of Main Specifications.....	60

- 1) **This camera is not resistant to water** and should not be used outdoors in snow or rain. If accidentally dropped in water, contact an authorized Canon service facility. Keep the camera out of salt spray and protect it from excessive humidity. If used at the beach, clean it thoroughly afterward with a dry cloth.
- 2) Do not attempt to disassemble the camera yourself. Always take it to an authorized Canon service facility for repair.
- 3) Remove the battery if you do not expect to use the camera for about three weeks or longer.
- 4) When storing the camera, wrap it in a clean, soft cloth and place it in a cool, dry, dust-free place. Be sure to keep the camera out of direct sunlight, and away from “hot spots” such as the trunk or rear window shelf of a car. Avoid places where moth balls are used, and in extreme humidity, use a desiccant.
- 5) Carefully check the camera’s operation after lengthy storage.
- 6) The battery may explode or cause burns if disassembled, recharged, shorted, exposed to high temperatures, or disposed of in fire.
- 7) Film passing through X-ray examinations at airports may be exposed and ruined even if loaded in the camera. Request a hand-checked inspection to avoid damage.
- 8) Aerosol spray dust removers are not recommended for the shutter curtain.
- 9) Condensation is a problem when bringing cold equipment into a warm room. If the autofocus optics cloud over, accuracy may be seriously affected. Before entering a warm room, put equipment in a plastic bag so that condensation forms on the outside of the bag.
- 10) Color reproduction may be adversely affected if film is left in the camera for a long time. Always develop exposed film promptly.
 - Please see page 58 for camera care information.

- Meaning of the **S** mark in this instruction book
 - S** Indicates functions available only on the Rebel X S.
 - Indicates Rebel X S functions which are also available on the Rebel X with an external flash.

Taking Photographs Straight Away

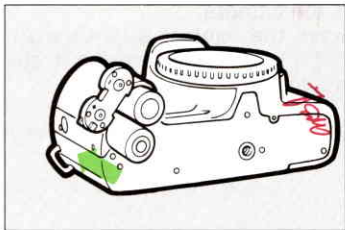

1. Load the batteries.
Insert two lithium batteries (CR123A/DL123A) into the camera as indicated.

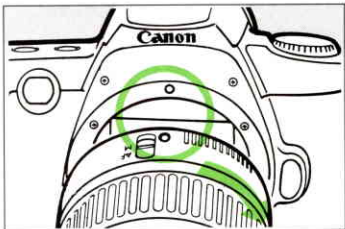

2. Attach the lens.
Align the red marks on the camera and lens, and turn the lens clockwise until it stops and locks with a click.

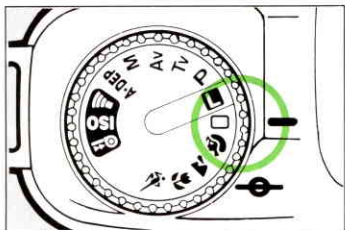

3. Set the command dial to □.

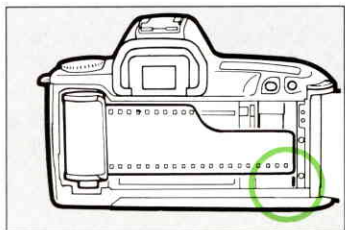

4. Load the film.
Align the film tip with the orange mark and close the back cover until it clicks securely shut.
 - The film will wind forward to the first frame.



5. Focus the camera.

Compose the subject within the AF frame ([]) and lightly press the shutter button to focus.

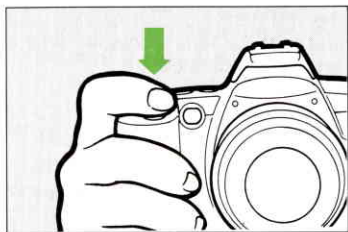

6. Take the photograph.

Press the shutter button down to take the picture.

7. Removing film.

When the last picture on a roll of film has been taken, the film will rewind automatically. When complete, open the back cover and remove the film.

Nomenclature

Self-timer Button
(see page 46)

Film Rewind Button
(see page 49)

LCD Panel (see page 9)

§ Flash Button
(see page 35)

§ Red-eye Reduction Mode
Button (see page 19)

Electronic Input Dial

Shutter Button
(see page 14)

Grip / Battery
Housing
(see page 11)

§ AF Auxiliary Light Emiter
(see page 18)

§ Red-eye Reduction Lamp
(see page 19)

§ Flash (see page 19)

Accessory Shoe (see page 40)
• For attaching Canon Speedlite
flashes and other optional
accessories.

Command Dial
(see page 10)

Strap Fixture
(see page 11)

Back Cover
Latch
(see page 15)

Lens Release Button
(see page 13)

Focus Mode Switch
(see page 13)

Zoom Ring

Manual Focussing Ring
(see page 52)

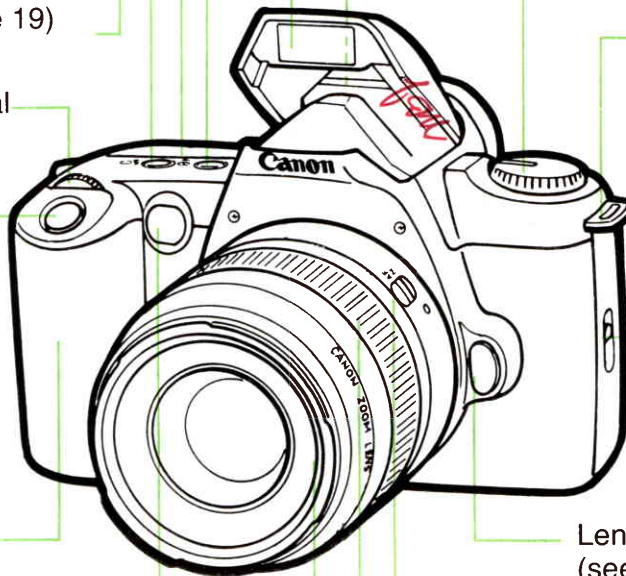

Nomenclature

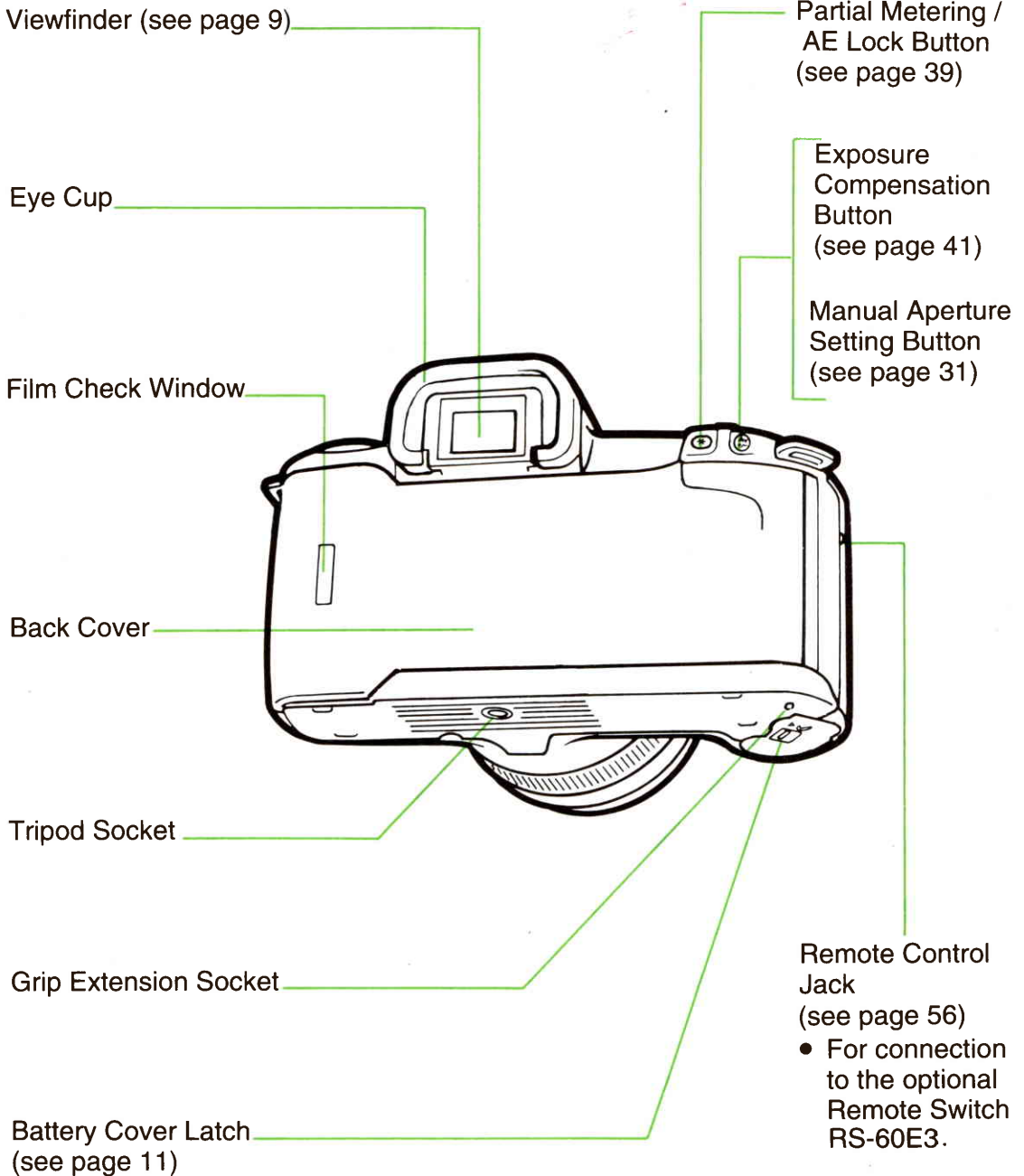

External LCD Panel

The following items are all indicated in the figure below.

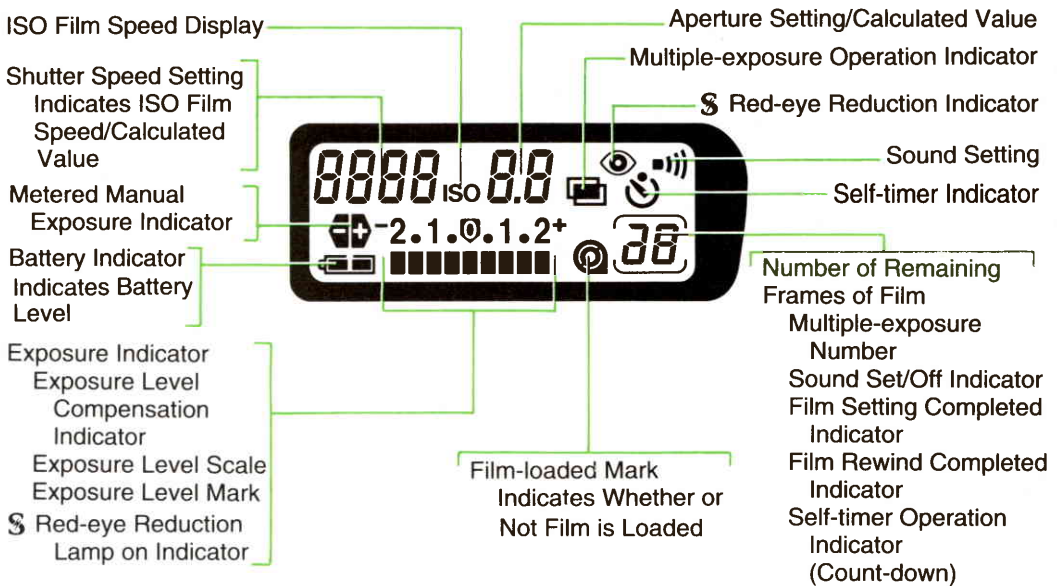

Viewfinder Internal Information Display

The following items are all indicated in the figure below.

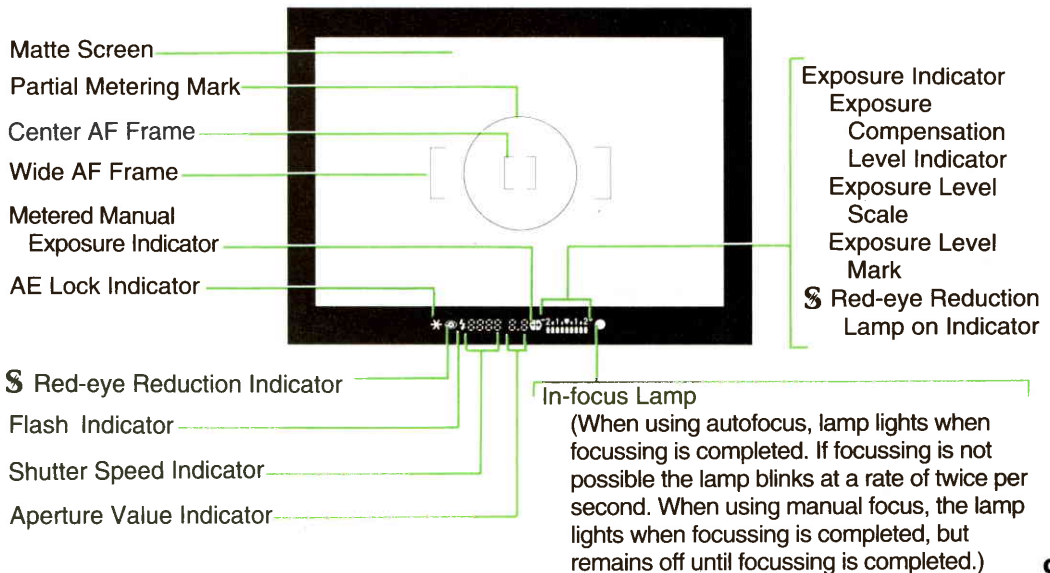

Command Dial

The settings on the command dial are situated around the **⏏** lock (OFF) position.

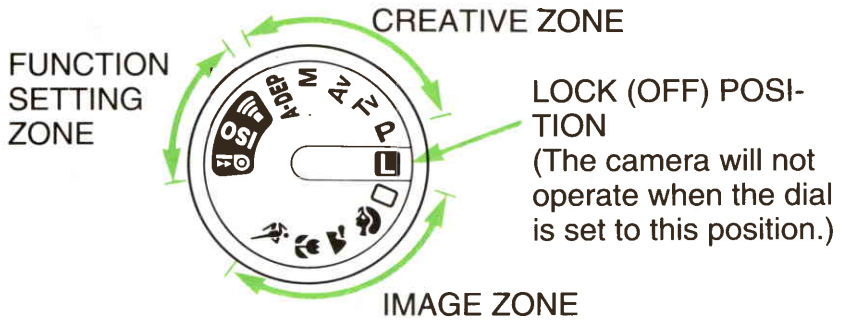

IMAGE ZONE

- : Sports (see page 24)
- : Close-up (see page 23)
- : Landscape (see page 22)
- : Portrait (see page 21)
- : Full Automatic (see page 17)

⏏ : Lock/(OFF)

CREATIVE ZONE

- P** : Program AE (see page 25)
- Tv** : Shutter-priority AE (see page 27)
- Av** : Aperture-priority AE (see page 29)
- M** : Manual Exposure (see page 31)
- A-DEP** : Automatic Depth-of-field AE (see page 33)

FUNCTION ZONE

- : Sound Mode (see page 48)
- ISO** : Manual ISO Speed (see page 47)
- : To Rewind Film before End of Roll (see page 49)



When the camera is not in use, please set the command dial to **⏏**. When the camera is placed in a bag, this prevents the possibility of objects hitting the shutter button, continually activating the shutter and draining the battery.

I. PREPARATIONS FOR TAKING PHOTOGRAPHS

An explanation of preparations which must be carried out before taking photographs and of the operation of the shutter button.

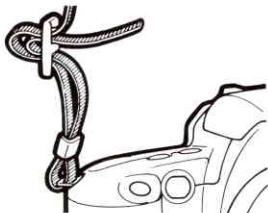

Attaching the Strap

Thread the ends of the neckstrap through the inside of the strap fixture as shown. Before using, tug the strap to ensure that it is firmly secured to the fixture.

Battery Loading and Checking Battery Level

Battery Loading

The camera uses two lithium batteries (CR123A/DL123A).

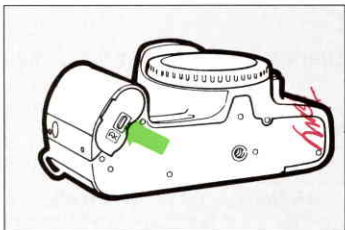

1. Slide the battery cover latch in the direction indicated so that the battery cover opens.

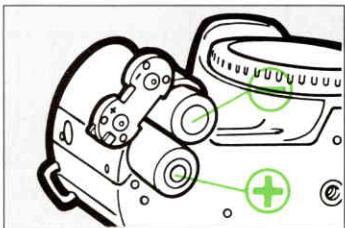

2. Insert the batteries with the + and - terminals pointing in the correct direction as indicated on the battery cover.
3. Close the battery cover.

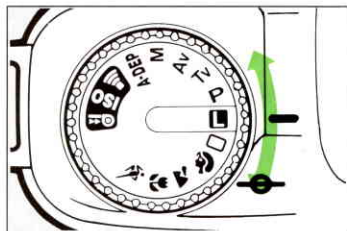

I. PREPARATIONS FOR TAKING PHOTOGRAPHS

Checking the Battery Level



1. Set the command dial to any setting in the image zone or creative zone, releasing the lock.

2. The battery check symbol will be displayed on the LCD panel. The battery check symbol indications have the follows meanings:

-  : The battery power is sufficient.
-  : Battery power is low. Please have new batteries ready.
-  : Replace both batteries with new ones.
- bc* : Please see page 58.

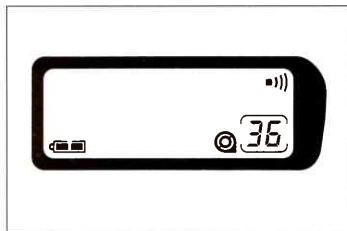

• The command dial lock must be released before a battery check can be carried out.

- Life of two lithium CR123A/DL123A batteries (number of rolls of film that can be taken).

Temperature	Without Flash	With 50% Flash	All Flash
Normal (+20 °C)	60 Rolls	25 Rolls	12 Rolls
Low (-10 °C)	35 Rolls	15 Rolls	7 Rolls

* Tests are based on new batteries, using the EF35-80mm f/4-5.6 II Lens and 24-exp. film. Data based on Canon's Standard Test Method.

* The shooting capacity will be reduced if the autofocus or shutter is used with no film in the camera.



- If there is nothing at all displayed on the LCD panel, check to see if the batteries are inserted upside down. Re-insert the batteries the correct way up.
- Always check the battery level before using the camera.
- Remember that batteries can sometimes be difficult to obtain in certain areas. Be sure to have an adequate supply when traveling overseas or when you expect to take large numbers of photographs.

How to Attach and Remove Lenses

Lens Attachment

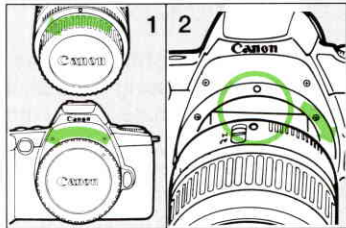

1. Remove the rear lens cap by turning it in the direction of the arrow.

2. Align the red marks on the lens and camera, and turn the lens in the direction of the arrow until it clicks.

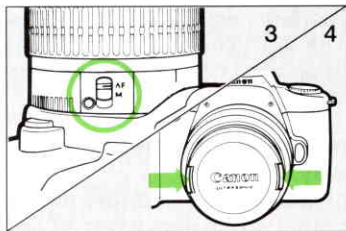

3. Set the focus mode switch on the lens to AF.

- If the switch is set to M, the autofocus can not be used.
- When using the autofocus, do not touch the rotating part of the lens.

4. Remove the front lens cap.

Removing the Lens



To remove the lens, turn the lens in the direction of the arrow on the lens while pressing the lens release button until it stops.

Shutter Button and Autofocus

The EOS shutter button has two stages. The first stage is reached by pressing lightly on the shutter button, and the second stage by pressing the button down completely. The shutter button operates as follows.

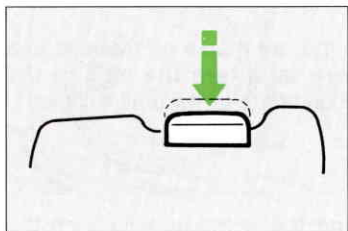

Pressing the shutter button halfway

- This initiates autofocussing (One-shot or Servo) and, once whatever you are shooting (the subject) is in focus, a short intermittent beeping sound is emitted and a green light in the viewfinder (the focus lamp) lights up.
- At the same time, the shutter speed and aperture combination (the exposure) is set. The values are displayed on the LCD panel and in the viewfinder.

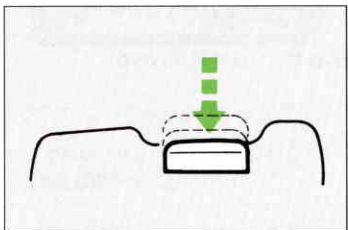

Pressing the shutter button down completely

- The shutter is released, the photograph taken and the film winds on one frame.



If the camera moves at the same moment as the shutter is released, this is called camera shake and can result in blurring of the entire photograph. In order to obtain sharp photographs, please take care of the following two points:

- Avoid moving the camera while taking a photograph.
- Always hold the shutter button at the half-way point before taking photographs.

Loading and Removing Film

How to Load Film

When a film is loaded, it is wound completely to the end. Then as each photograph is taken, the film rewinds frame by frame. The number of photographs remaining out of the total on the roll of film is continually displayed.

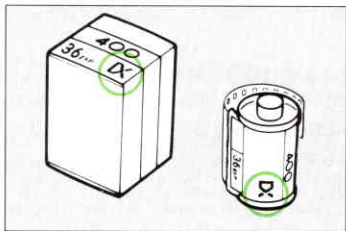

The film has a DX code attached to, allowing the film speed to be set automatically.

- If your film has no DX code on it, the film speed must be set manually. Please read the section “Changing the Film Speed Setting” on page 47.

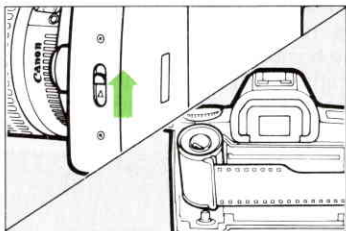

1. Release the command dial lock by setting to any position other than **L**.
2. Open the back cover by raising the back cover latch.
3. Insert the film as shown in the picture, placing one end in first.

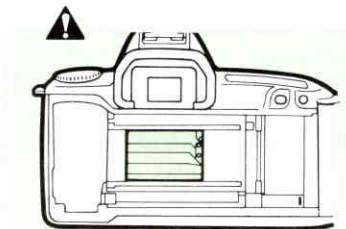

The shutter curtain is an extremely high precision mechanism and must never be touched. When loading film, be careful not to allow your fingers or the tip of the film to come in contact with the shutter curtain, as this can cause damage.

I. PREPARATIONS FOR TAKING PHOTOGRAPHS

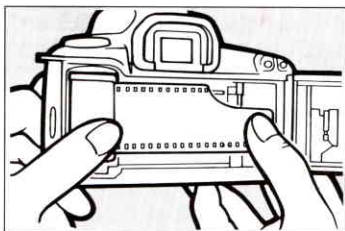

4. Align the tip of the film with the orange mark.

- To ensure that the film lies flat, press lightly on the film cartridge.
- If too much film is protruding, rewind the film cartridge slightly.

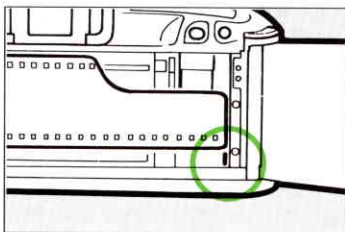

5. Ensure that the film is aligned with the orange mark before closing the back cover.

The film will then begin to wind forward, and the number of available frames will begin to rise. When this has been completed, you will hear a click like that of the shutter release, and the film-loaded mark (Ⓢ) and the number of available frames will appear on the LCD panel.

- If the number of available frames does not appear, this means that the film has not been loaded correctly. Re-load the film correctly.

Removing the Film

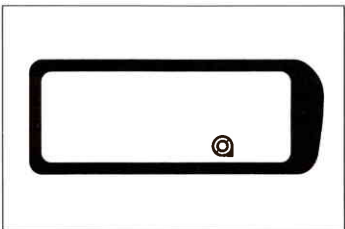

After the last frame on the film has been taken, the film will automatically begin rewinding.

When the film has finished rewinding, the film mark only will appear on the LCD panel. After checking the display, open the back cover and remove the film.

II. TAKING PHOTOGRAPHS

Here we explain a simple way of taking photographs using the image zone on the command dial. Using the settings in the image zone, when the shutter button is pressed the camera takes over, setting everything automatically for your photograph. The various automatic settings possible are shown on page 54 in the section “List of Functions that can be Used Together”. Note that not all combinations are possible.

Taking Photographs on the Full Automatic Mode (□)

Taking photographs on the full automatic mode allows you to take shots of all kinds of subjects with no fuss. As long as the subject is covered by the AF frame, anyone can obtain good results with ease.

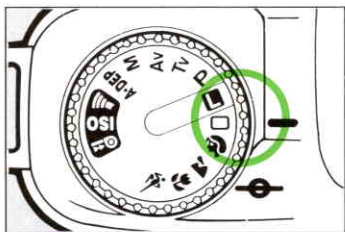

1. Set the command dial to □ .

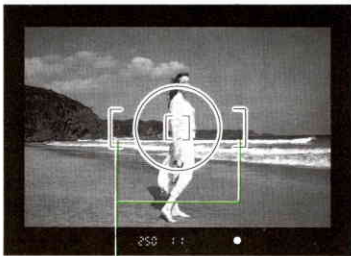

Wide AF Frame

2. Look through the viewfinder and cover the subject with the Wide AF Frame.
- If you wish to focus on a subject outside the Wide AF Frame, see the section “Focussing on Subjects at the Edge of the Viewfinder” on page 20.

II. TAKING PHOTOGRAPHS

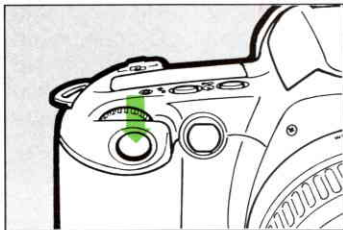

3. Press the shutter button halfway. The subject is brought into focus, and the shutter speed and aperture are set.

- A green lamp in the viewfinder (the focus lamp) lights up.
- The shutter speed and aperture value are displayed both on the LCD panel and in the viewfinder.



4. Press the shutter button all the way down to take the picture.



•Blinking shutter speed (camera shake warning)

In the image zone, if there is a danger of a slow shutter speed resulting in camera shake, the shutter speed indicated on the LCD panel and in the viewfinder will blink. If this occurs although you have been holding the camera steadily and taking care how you press the shutter button, we recommend using a tripod. (Even when using a tripod, however, it is still possible for the shutter speed to blink if there is a danger of camera shake.)

•Blinking focus lamp



When the focus lamp blinks, the shutter cannot be released. Please see page 52.

S The AF Auxiliary Light Emitter

When focussing conditions are difficult, the AF auxiliary light emitter comes on automatically to illuminate the subject, making focussing easier.

- The AF auxiliary light emitter can operate in both the image zone and the creative zone.

§ Automatic Flash

When the command dial is set to , ,  in the image zone, the flash will automatically pop up and fire if the subject is dark or in back-lit conditions where the background is too bright against the subject.



If you wish to take a photograph without using the flash, such as in places where flash photography is forbidden or for indoor shots where you wish to make use of the available lighting, simply press the shutter button halfway, then push the built-in flash down gently to retract. You can then take your photograph without the flash.



§ Red-eye Reduction when Using the Flash

In photographs of people taken using a flash at night or in poorly-lit interiors, the subject's eyes may appear red. This is due to light reflected from the retina, and the phenomena is called "red eye".

When taking a flash shot with the camera set to the red-eye reduction function, the red-eye reduction lamp lights up, gently illuminating the subject's eyes momentarily, reducing the size of the pupils and reducing the chance of the red-eye phenomena occurring.

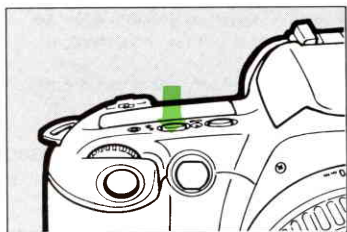
When using the image zone, the red-eye reduction function can be set in the following way.



1. Press the red-eye reduction mode button (the flash button).
 - The LCD panel will display the  mark to indicate that the red-eye reduction has been set.
2. To switch the red-eye reduction function off, press the flash button one more time.
 - The  mark on the LCD panel will go out, indicating that the red-eye reduction function has been switched off.

II. TAKING PHOTOGRAPHS



- When the red-eye reduction lamp is on, the shutter will be released about 1 second after the shutter button is completely pressed down.
- When the red-eye reduction lamp is on, the display in the viewfinder will indicate this with the  mark.



The red-eye reduction lamp is effective when the subject is looking towards it, however the level of effectiveness can vary from person to person.

Focussing on Subjects at the Edge of the Viewfinder

When taking photographs where the subject is outside the center focus mark in the viewfinder, focus in the following way:



1. Cover the subject you wish to have in focus with the AF frame and press the shutter button halfway.

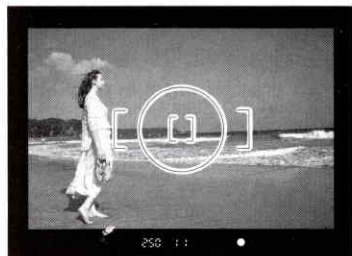

2. Keeping the shutter button pressed halfway, recompose the picture.
3. Press the shutter button all the way down to take the picture.

Taking Photographs in Portrait Mode ()

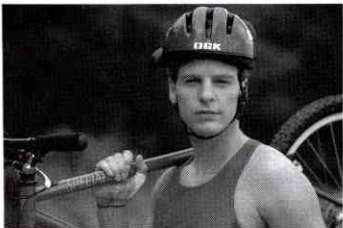

Use this setting when you wish to take a photograph with the subject in the foreground clearly emphasized against a blurred background.

- By pressing the shutter button down and holding it, continuous shooting is possible.
- S** If the subject appears dark against a bright background, the flash will fire automatically.

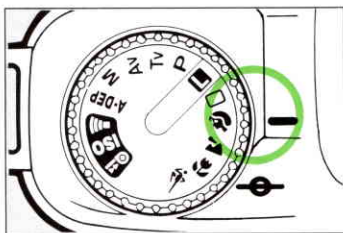

Set the command dial to .





- If the subject's head and shoulders fill up most of the center of the viewfinder, an effective background blur can be achieved. In addition, a better effect can be achieved with the subject as far away from the background as possible.
 - A more effective background blur can be achieved when using a telephoto lens. If using a zoom lens, set the lens to the telephoto setting (80mm in the case of a 35-80mm lens).
- S** If  blinks in the viewfinder, attach an external flash unit and use flash when taking the picture.

Taking Photographs in Landscape Mode ()

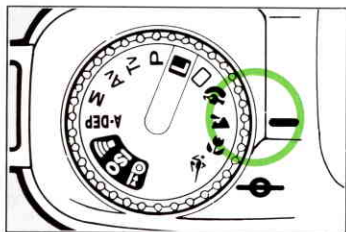

For expansive landscapes, sunset shots and night-time photographs, please use the landscape setting.



This setting is indicated as  on the command dial.



When using your zoom lens, use the wide-angle setting (35 mm in the case of a 35-80mm lens). This will create a feeling of expansiveness and add depth to your photographs.



- If the built-in flash pops up when you set the command dial to , press the flash gently down until it retracts before shooting. You will not be able to take the picture as you see it if the flash is left on.
- If the shutter speed indicator blinks, there is a danger of camera shake, so be sure to hold the camera steady and take care how you press the shutter button. Otherwise we recommend using a tripod. (Even when using a tripod, however, it is still possible for the shutter speed to blink if there is a danger of camera shake.)

Taking Photographs in Close-up Mode (🌱)

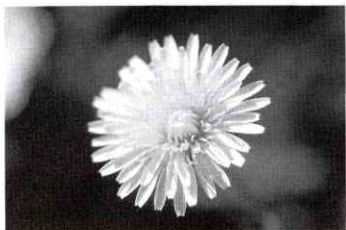

Use the macro function built in to your lens for close-up photography when you want to take photographs of plants and insects in maximum magnification. **S** If the subject is dark or back-lit by, the built-in flash will fire automatically.

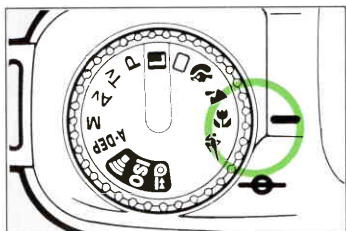

Set the command dial to 🌱.



- Take your photograph from as close to the subject as your lens permits.
- When using a zoom lens, you can achieve a higher level of magnification in your photograph by setting the lens to telephoto.
- For full-scale macro photography, we recommend our optional macro lenses and ML-3 macro ring light.

S If 🌱 blinks in the viewfinder, attach an external flash unit and use flash when taking the picture.

Taking Photographs in Sports Mode ()



Please use this setting when you wish to freeze fast-moving subjects, such as sports activities and events.

- If you keep the shutter button pressed down, continuous photographs can be taken.

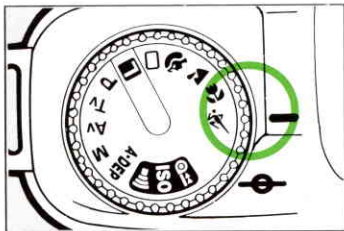

Set the command dial to .



- We recommend that you use film with a speed of ISO 400 or over.
- We also recommend telephoto lenses for sports photography, such as the EF80-200mm f/4.5 - 5.6 USM, EF75 - 300mm f/4 - 5.6 USM, etc.



S If the built-in flash pops up when you set the command dial to , press the flash gently down until it retracts before shooting. You will not be able to take the picture as you see it if the flash is left on.

- If the shutter speed indicator blinks, there is a danger of camera shake, so be sure to hold the camera steady and take care how you press the shutter button. Otherwise we recommend using a tripod. (Even when using a tripod, however, it is still possible for the shutter speed to blink if there is a danger of camera shake.)

III. TAKING DIFFERENT KINDS OF SHOTS

Here we will explain how to use the wide range of functions built into the camera when the command dial is set to the creative zone. The functions available on the creative zone setting allow you to precisely determine the results you want to achieve.

Taking Photographs on the Program AE Settings (P)



Setting the camera to this setting is just as easy as setting to the (□) full auto mark. The camera sets both shutter speed and aperture automatically to match the brightness of the subject. This function is called Program AE.

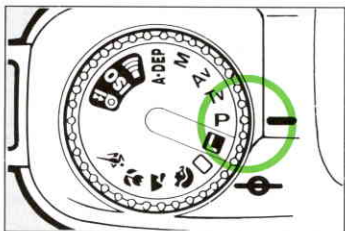

1. Set the command dial to **P** .



When using the creative zone, the LCD panel and the viewfinder will display the shutter speed, the exposure level scale as well as the exposure level mark. The exposure level mark indicates the exposure level when using the exposure compensation or when selecting the exposure manually.

III. TAKING DIFFERENT KINDS OF SHOTS

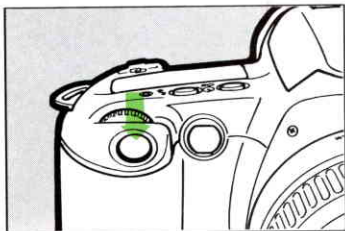

2. Press the shutter button halfway to focus on the subject.
 - The shutter speed and aperture will be indicated on the LCD panel and in the viewfinder.



3. Check the shutter speed and the aperture and take the photograph.

Program Shift

In Program AE mode, the automatically set shutter speed and aperture combination can be changed while maintaining the same exposure. This function is called Program Shift.

To shift the program, press the shutter button halfway and turn the electronic input dial to select the desired shutter speed or aperture value.

- After taking a photograph the Program Shift switches off automatically and returns to the original program.
- Program Shift is not possible when using a flash.

Six-second Timer

Even if you release the shutter button after pressing it down halfway, the exposure data (shutter speed and aperture) in the viewfinder and LCD panel appear for about six seconds.

Shutter-priority AE Settings (Tv)

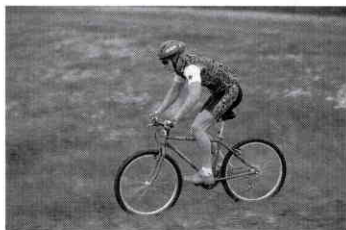

Fast shutter speed

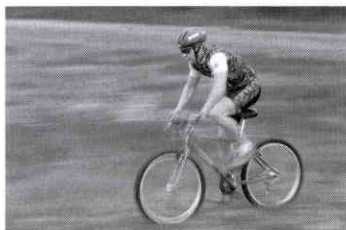

Slow shutter speed

At the shutter-priority setting, the camera automatically sets the aperture value for the lighting conditions. This is called Shutter-priority AE.

Faster shutter speeds allow you to take photographs that freeze moving subjects, while with slower shutter speeds you can capture objects with a feeling of motion.



If you set the shutter speed at 1/15 sec you can take clear pictures of your television set screen.

- When taking a photograph of a TV screen, be sure to hold the camera very steady, or use a tripod.

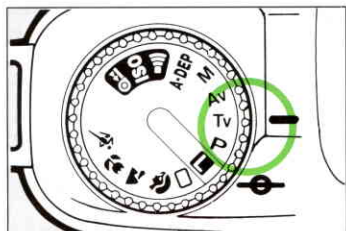

1. Set the command dial to Tv .

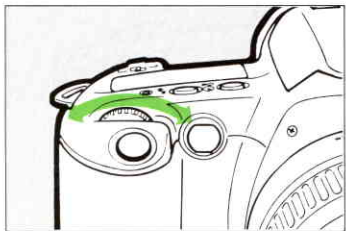

2. Turn the electronic input dial to the desired shutter speed setting.

III. TAKING DIFFERENT KINDS OF SHOTS

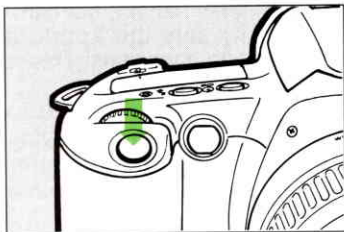

3. Press the shutter button halfway to focus on the subject.
 - The shutter speed and aperture will be indicated on the LCD panel and in the viewfinder.



4. Check the shutter speed and the aperture and take the photograph.



- If the smallest aperture value (i.e. maximum aperture) of the lens blinks in the viewfinder, reduce the shutter speed by turning the electronic input dial until the blinking stops.



- If the largest aperture value (i.e. minimum aperture) of the lens blinks in the viewfinder, increase the shutter speed by turning the electronic input dial until the blinking stops.



Aperture-priority AE Settings (Av)



Smaller aperture value



Larger aperture value

When you set the aperture, the camera automatically selects the correct shutter speed to suit the lighting conditions around the subject. This is called Aperture-priority AE.

A smaller aperture value (i.e. larger aperture) is suitable for taking beautiful portrait photographs, with effectively graduated or blurred backgrounds. However, with a small aperture value, landscapes will blur.

A larger aperture value (i.e. smaller aperture) gives a greater depth-of-field suitable for clear photographs of expansive landscapes, where everything from nearby objects to background details are sharply in focus.

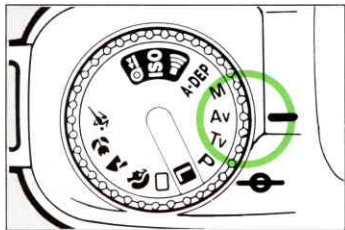

1. Set the command dial to Av .

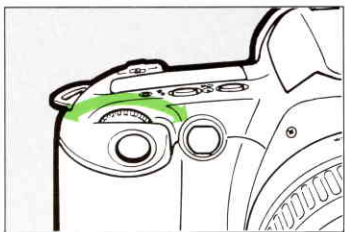

2. Turn the electronic input dial to the desired aperture value.

III. TAKING DIFFERENT KINDS OF SHOTS

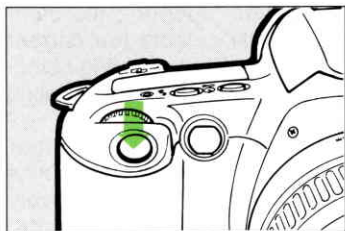

3. Press the shutter button halfway to focus on the subject.
 - The shutter speed and aperture will be indicated on the LCD panel and in the viewfinder.



4. Check the shutter speed and the aperture and take the photograph.



- If the shutter speed blinks at 30", turn the electronic input dial to reduce the aperture value until the blinking stops.



- If the shutter speed blinks at 2000, turn the electronic input dial to increase the aperture value until the blinking stops.



Manual Exposure Settings (M)

Rather than leaving everything to the camera, this mode allows you take artistic photographs by selecting the shutter speed and aperture value yourself. You can check that the combination of shutter speed and aperture value is suitable by checking the exposure level mark on the exposure level scale.

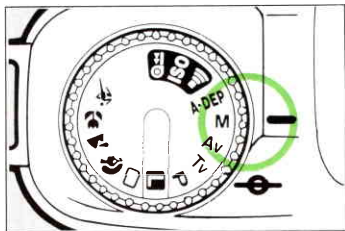

1. Set the command dial to **M**.

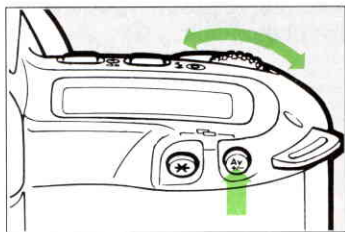



2. Turn the electronic input dial to set the desired shutter speed.

3. While pressing the manual aperture setting button, turn the electronic input dial to set the desired aperture value.

4. Press the shutter button halfway to focus on the subject.
 - The shutter speed and aperture will be indicated on the LCD panel and in the viewfinder.



Correct exposure	
Overexposure	
Underexposure	

5. Adjust the exposure according to the exposure level mark.

Correct exposure: This is the metered standard which will set the exposure.

Overexposure: Select a faster shutter speed or adjust the aperture until correct exposure is obtained.

Underexposure: Select a slower shutter speed or adjust the aperture until correct exposure is obtained.

6. When correct exposure is obtained, take the photograph.